

HEAVY DUTY FEED WHEEL TENSIONER

TOOL MAINTENANCE

This tool has been thoroughly inspected and tested before shipment. It is designed for hard wear and long service.

The following simple instructions will aid you in prolonging the serviceability of this tool: Clean this tool periodically with a wire brush. Apply light machine oil to all moving parts.

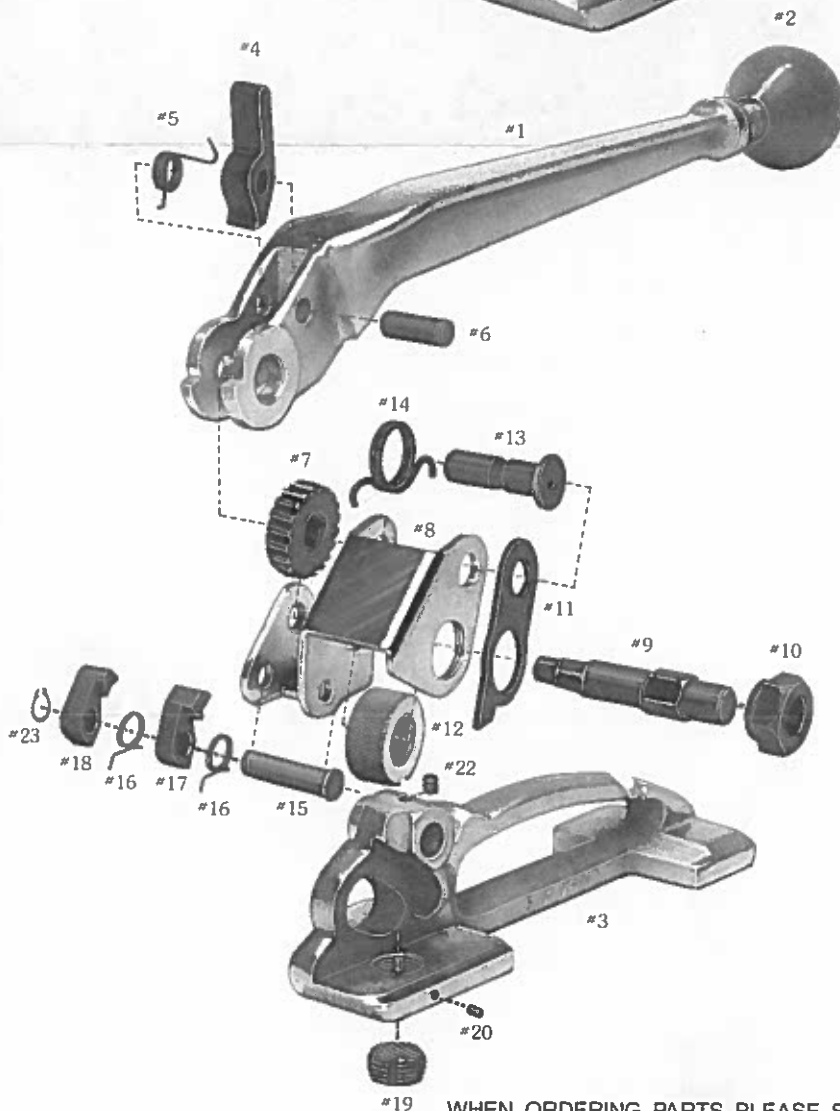
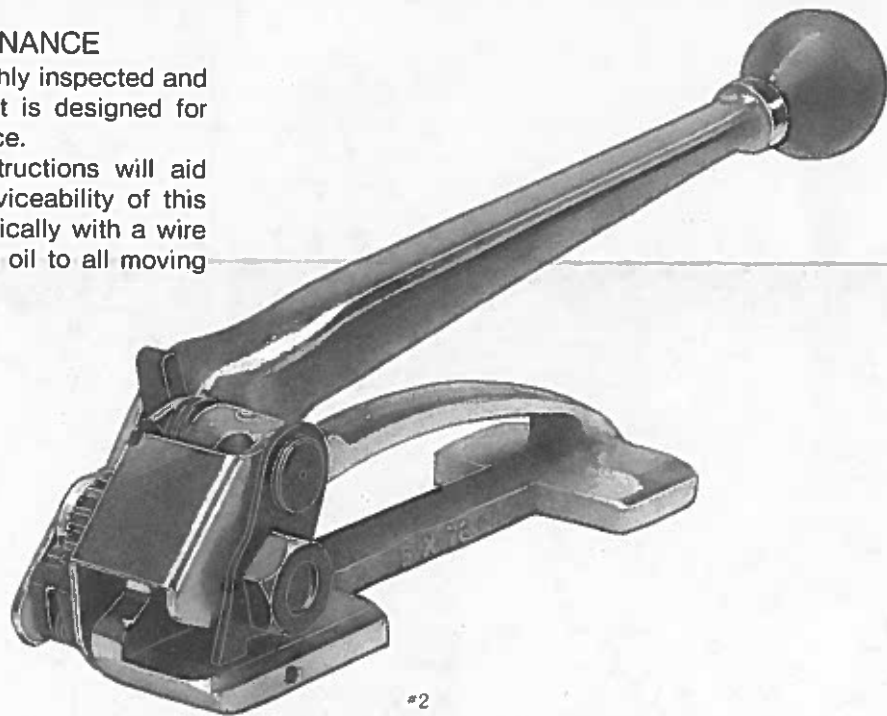

PARTS LIST

Part No.	DESCRIPTION	Qty.
= 1	Handle	1
= 2	Knob	1
= 3	Base	1
= 4	Handle Pawl	1
= 5	Handle Pawl Spring	1
= 6	Crosshead Pin	1
= 7	Ratchet Gear	1
= 8	Support Frame	1
= 9	Shaft	1
= 10	Big Nut	1
= 11	Support Frame Plate	1
= 12	Feedwheel	1
= 13	Support Pin	1
= 14	Feedwheel Support Spring	1
= 15	Retaining Pawl Pin	1
= 16	Pawl Spring	2
= 17	Long Pawl	1
= 18	Short Pawl	1
= 19	Clutch Plug	1
= 20	Set Screw	1
= 22	Set Screw	1
= 23	S8 Clip	1

#19 WHEN ORDERING PARTS PLEASE SHOW TOOL MODEL, PART NUMBER AND NAME.
WEARING PARTS ARE USUALLY LIMITED TO THOSE UNDERLINED.